

ALL OPERATIONS MUST BE CARRIED OUT BY QUALIFIED PERSON

- ① Rimuovere il sacchetto protettivo che avvolge dalla lampada.

Remove the protective bag that wraps around the lamp.

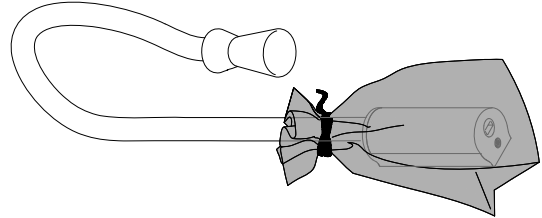

- ② Rimuovere la vite dal pannello inferiore della lampada.

Remove the screw from the lower panel of the lamp.

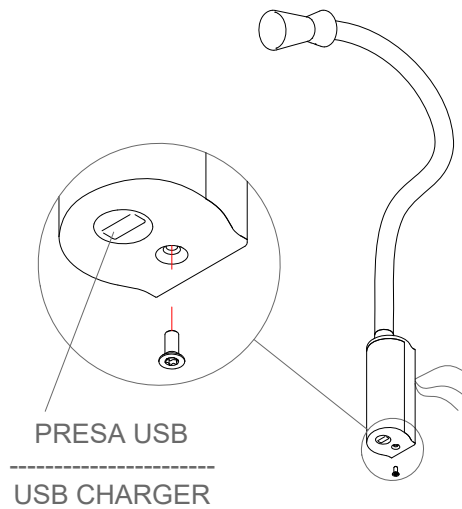

- ③ Estrarre la placca anteriore facendola scorrere verticalmente.

Remove the front plate by sliding it vertically.

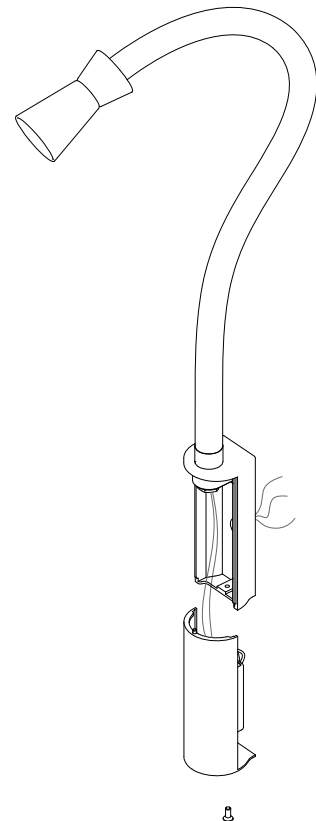

- ⚠ Al fine di evitare che il componente si possa danneggiare consigliamo di avvolgere la placca anteriore con il sacchetto in cui è imballata la lampada.

In order to prevent the component from being damaged, we recommend wrapping the front plate with the bag which the lamp is packed in.

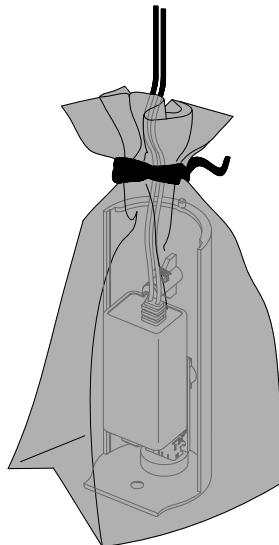

ALL OPERATIONS MUST BE CARRIED OUT BY QUALIFIED PERSON

- ④ Fissare la placca posteriore alla parete utilizzando le viti adeguate.

Fasten the backplate to the wall using the appropriate screws.

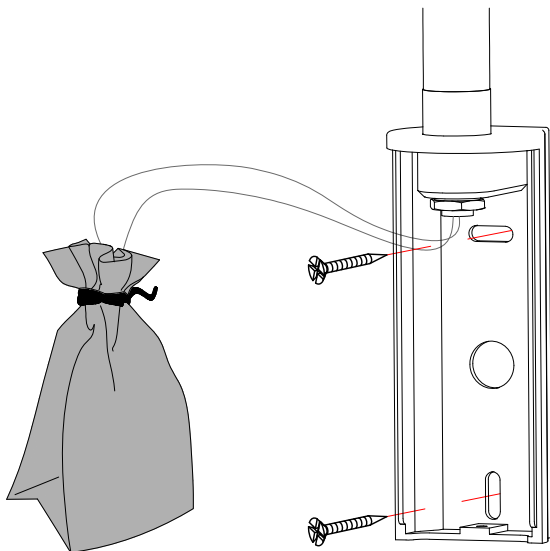

Il cablaggio fornito in dotazione è conforme alle normative USA e CE.

A discrezione del montatore consigliamo durante l'operazione di collegamento di gestire il cavo in eccesso accorciandolo utilizzando le morsettiere in dotazione.

The wiring supplied is compliant with the USA and CE regulations.

At the discretion of the fitter we recommend during the connection operation to manage the excess cable by shortening it using the supplied terminal blocks.

- ⑤ Eseguire il cablaggio come nello schema illustrato.

Carry out the wiring as shown in the diagram.

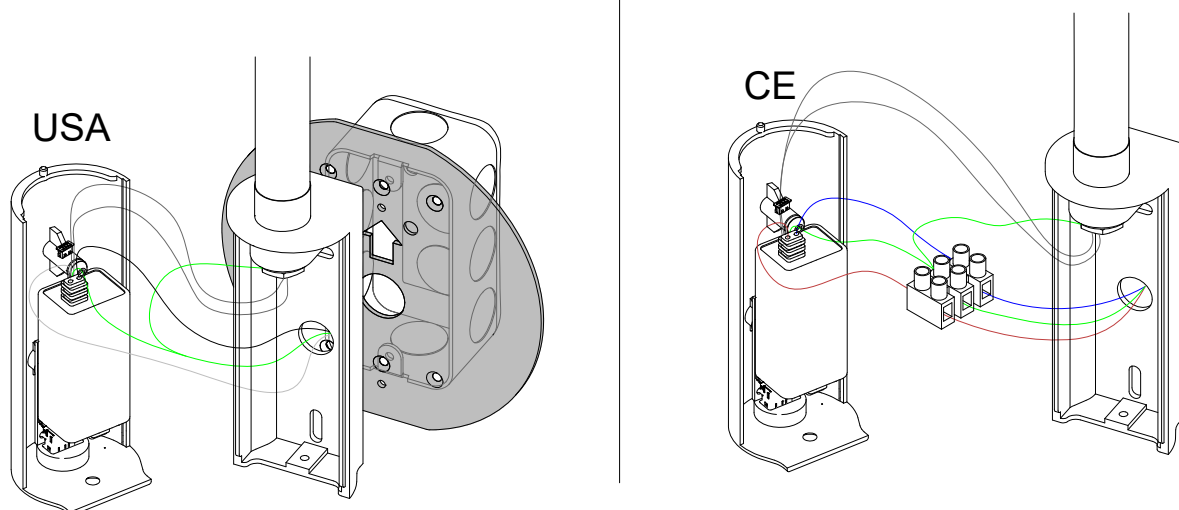

- ⑥ Riposizionare la placca anteriore e chiudere la lampada stringendo la vite inferiore. Attenzione a non danneggiare i cavi interni durante questa operazione.

Reposition the front plate and close the lamp by tightening the screw below. Be careful not to damage the internal cables during this operation.